



Industrie Service

# EU-TYPE EXAMINATION CERTIFICATE

According to Annex IV, Part A of Directive 2014/33/EU

**Certificate No.:** EU-SG 489

**Certification Body of the Notified Body:** TÜV SÜD Industrie Service GmbH  
Westendstr. 199  
80686 Munich – Germany  
Identification No. 0036

**Certificate Holder:** INVENTIO AG  
Seestrasse 55  
6052 Hergiswil – Switzerland

**Manufacturer of the Test Sample:** Schindler Drive Systems  
Poligono “Empresarium”  
Albardin, 58  
(Manufacturer of Serial Production - see Enclosure)  
50720 La Cartuja Baja - Zaragoza – Spain

**Product:** Progressive safety gear and braking device as part of the protection device against overspeed for car moving in upwards direction

**Type:** SA GED 10  
ID-No.: 59378100

**Directive:** 2014/33/EU

**Reference Standards:** EN 81-20:2014  
EN 81-50:2014

**Test report:** No. EU-SG 489 of 2017-12-20

**Outcome:** The safety component conforms to the essential health and safety requirements of the mentioned Directive as long as the requirements of the annex of this EU-type examination certificate are kept.

**Date of Issue:** 2017-12-20

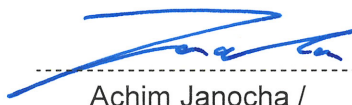
  
Achim Janocha /

Certification Body “lifts and cranes”



**Annex to the EU-Type Examination Certificate  
No. EU-SG 489 dated 2017-12-20**



Industrie Service

**1 Scope of application**

1.1 General

All following application possibilities refer to a brand-new pair of safety gear, depending on manufacturing method, condition running surface of guide rail and tripping speeds. The safety device can fulfil two security features.

Guide rails to be used

Minimum running surface width 25 mm

Blade width 8 – 16 mm

1.2 Using as a progressive safety gear (working in down direction) - Permissible total mass of car plus rated load and rated speed

Guide rail manufactured by	Condition of the running surface	Max. rated speed [m/s]	Max. tripping speed [m/s]	Total mass [kg] min. – max.
drawn	dry	2.18 – 2.37	2.73	457 – 1670
	oiled*	2.03 – 2.31	2.33	664 – 2519
machined	dry	2.56 – 2.87	3.30	590 – 2478
	oiled*	2.56 – 2.87	3.30	577 – 2590

\*HLP – oils according DIN 51524, part 2

1.3 Using as a brake device – Part of protection device against overspeed for car moving in upwards direction (working in up direction) - Permissible brake forces

Guide rail manufactured by	Condition of the running surface	Max. tripping speed [m/s]	Brake force [N] min. – max.
drawn	dry	2.21	3244 – 7563
	oiled*	2.21	2816 – 8406

\*HLP – oils according DIN 51524, part 2

## 2 Conditions

- 2.1 The above mentioned safety component represents only part of a protection device against overspeed for car moving in upwards direction. Only in combination with a detecting and triggering component (two separate components also possible), which must be subjected to an own type examination, can the system created fulfil the requirements of the protection device.
- 2.2 The forces acting on the guide rails must be safely absorbed.
- 2.3 The dimension configuration of the lift system must be designed as regards the total mass and brake forces in such a way, that the permissible value of deceleration according norm EN 81-20 does not exceed.(e.g. empty lift car travelling in upwards direction is not decelerated by more than 1 g<sub>n</sub>).
- 2.4 For identification and information about the principal construction and operation and for demarcation of the examined and approved sample the identification drawing M \_\_ 41378100 with certification stamp dated 2013-03-28 has to be enclosed to the EU-type examination certificate and its annex.
- 2.5 The EU-type examination certificate may only be used in connection with the pertinent annex and the enclosure (list of the manufacturers serial production). This enclosure shall be updated and re-edited following information of the certificate holder.

## 3 Remarks

- 3.1 Due to the characteristics, the braking force for the progressive safety gear acting downwards and the braking force for the brake device acting upwards are permanently related to each other. They cannot be adjusted separately in principle. The permissible total mass stated in scope of application thus also is permanently related to the permissible braking force.
- 3.2 Pursuant to the standard EN 81-50:2014, paragraph 5.3.4, the total mass of the progressive safety gear determined for adjustment purposes may be 7.5 % higher or lower.
- 3.3 The progressive safety gear based on permissible total mass according table point 1.2 of this type examination certificate can also be used till maximum permissible tripping speed by the counterweight.
- 3.4 This EU-type examination certificate is based modelled after and /or harmonized standards as following:
  - EN 81-1:1998 + A3:2009 (D), Anhang F.3
  - EN 81-2:1998 + A3:2009 (D), Anhang F.3
  - EN 81-20:2014 (D), Punkt 5.6.2.1.1.2
  - EN 81-50:2014 (D), Punkt 5.3
- 3.5 Changes resp. extensions of the upper mentioned standards or a further development of the state of the art may make a revision of this EU-type examination certificate necessary.



Enclosure of EU-Type Examination Certificate  
No. EU-SG 489 dated 2017-12-20



Industrie Service

**Authorised Manufacturer of Serial Production – Production Sites (Stated: 2017-12-20):**

**Company** Schindler Drive Systems  
**Address** Poligono "Empresarium"  
Albardin 58  
50720 La Cartuja Baja - Zaragoza – Spain

**Company** Schindler (China) Elevator Co., Ltd.  
**Address** No. 818 Jin Men Road  
215004 Suzhou – P.R. China

**Company** Schindler (China) Elevator Co., Ltd.  
**Address** No. 588 Xing Shun Road, Jiading District,  
Shanghai – P.R. China

**Company** Elevadores Atlas Schindler S. A.  
**Address** R. Angelina Ricci Vezozzo, 3400  
86087 Londrina – Brasil

**Company** Hebei Dongfang Fuda Machinery Factory  
**Address** No. 112, Guangming East Avenue, Langfang City  
Heibei Province 065000 – P.R. China

- END DOCUMENT -

Installation example

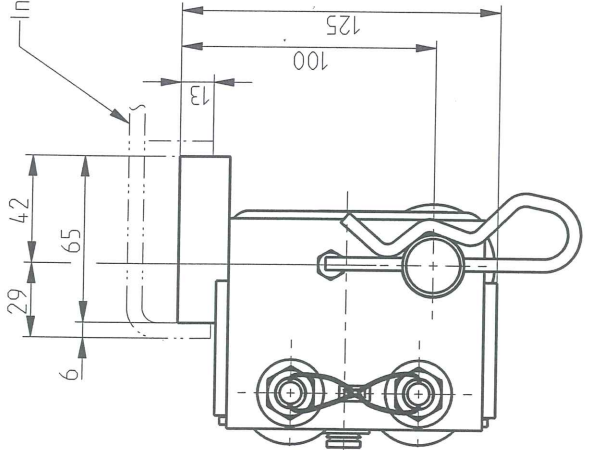

Safety Gear SA GED 10 left

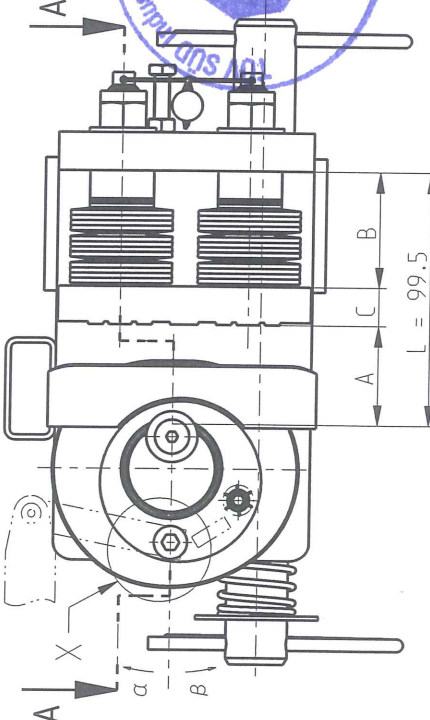

Safety Gear SA GED 10 right

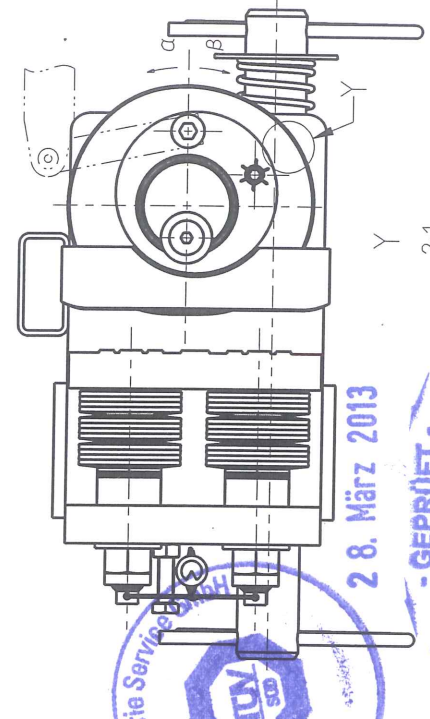

28. März 2013

**- GEPRÜFT -**  
 TÜV SÜD Industrie Service GmbH  
 Zentralbereich Fördertechnik-Sonderbauten  
 Abteilung Aufzüge und Sicherheitsbauteile  
 Westendstr. 199, D-80686 München  
 Der Sachverständige  
*[Signature]*

Notes:

- The Safety Gear SA GED 10 works in up direction and down direction.
- Actuating force  $F = 60N$  for 1 pair SA GED 10 (without retaining spring) according to detail B
- $\alpha$  rotating angle for up direction
- $\alpha \sim 45^\circ$  contact of the braking elements with the guide rail
- $\alpha \sim 150^\circ$  brake position (maximum rotation angle)
- $\beta$  rotating angle for down direction
- $\beta \sim 45^\circ$  contact of the braking elements with the guide rail
- $\beta \sim 105^\circ$  brake position (maximum rotation angle)
- Drawn version SA GED 10/AS with BFK 10
- Guiding rails information according ISO7465:2007 (E)

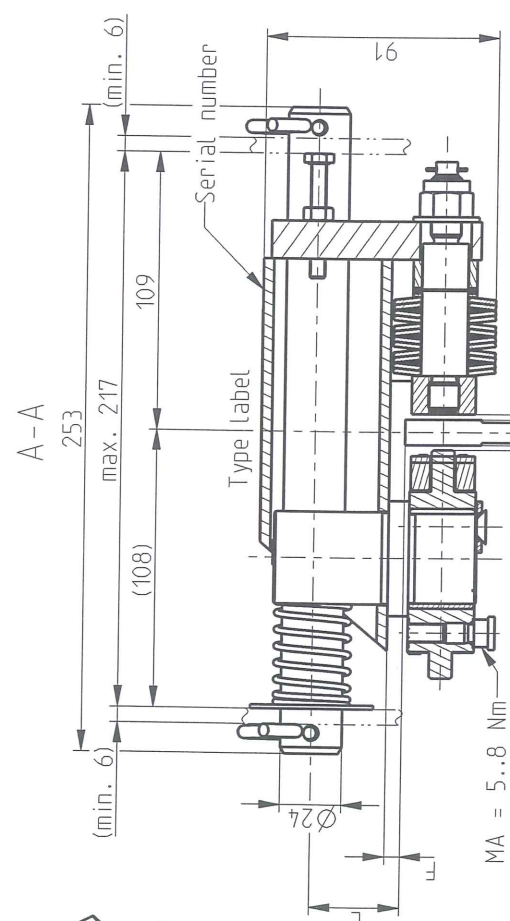

Example:

T89/A	16	62.0	45.0	39.5	15	34.0	35.0	6.0	2
T75/A	10	62.0	39.0	45.5	15	30.0	35.0	6.0	2
T82/A	9	68.0	38.0	44.5	17	34.0	35.0	6.0	2
T70/A	9	65.0	38.0	44.5	17	34.0	35.0	6.0	2
Type	BFK	HFP	A	B	C	D	E	F	S

59378100	Semi finished product / raw material	Semi fin. Ident. No.	Item	Code surface	Heat Treatment	Drawng / Weight	12.02/4
Modification			A60	Draw Ver.	Retained BOH	BM / Model	
KA No.			159289	23	Retained BOH		
KA Date			2013-05-01	Model Ver.	Release Level		
GROUP: SAFETY			Remark	1/4	Released		
Dimensioned Drawing SA GED 10			Scale	Replaces /Ae	Prepared	Date	
SA GED 10			1:2		Reviewed	2013-03-11	puerbelu
					Norms checked	2013-03-11	eggeran
					Released	2013-03-11	eggeran
							getssmii
Classification			Lead office	Lang.		EN	
T/540			EB3	M__41378100			
Format A3							

This presentation is our intellectual property. Without our written consent, it shall neither be copied in any manner, nor used for manufacturing. This presentation is our intellectual property. Without our written consent, it shall neither be copied in any manner, nor used for manufacturing. This presentation is our intellectual property. Without our written consent, it shall neither be copied in any manner, nor used for manufacturing.